

Fjerning av pinnebein i umodnet laks – utfordringer ved utvikling av ny metode

Ulf Erikson

OVERSIKT

Pre-rigor fjerning av pinnebein

1. Konseptet pre-rigor fjerning av pinnebein
2. Biologiske rammer
3. Elektrobødøving ★
4. Endringer i filetens fysiske/kjemiske egenskaper på prosesslinjen(e)
5. Energiinnhold i muskelen ved død ★
6. Pinnebein i laksemuskel
7. To metoder for fjerning av pinnebein
8. Ny metode for fjerning av pinnebein
9. FoU-plan

Postmortem processing – Fillet line

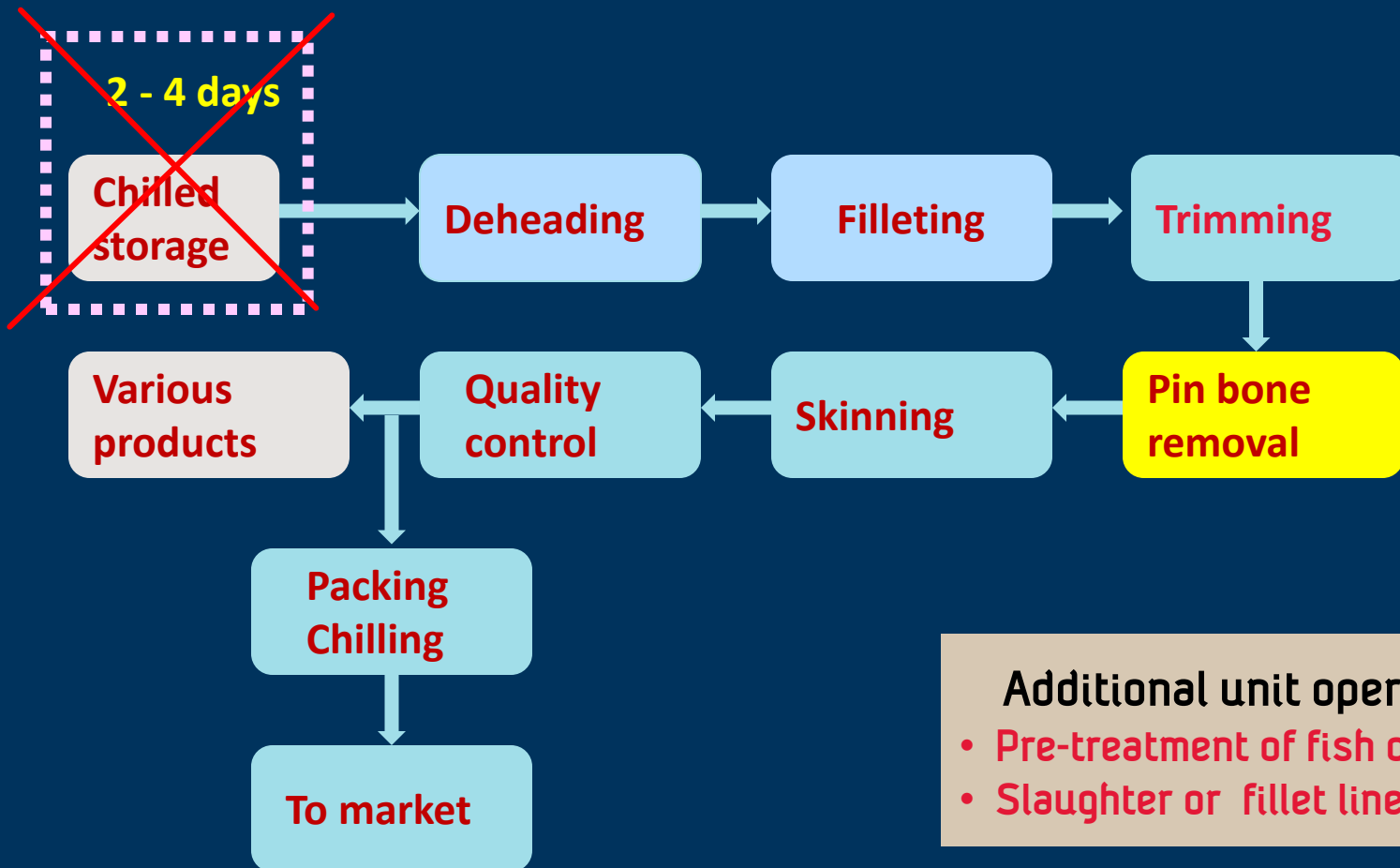

Pre-slaughter handling: Waiting cage (or well-boat) Crowding and pumping to processing line

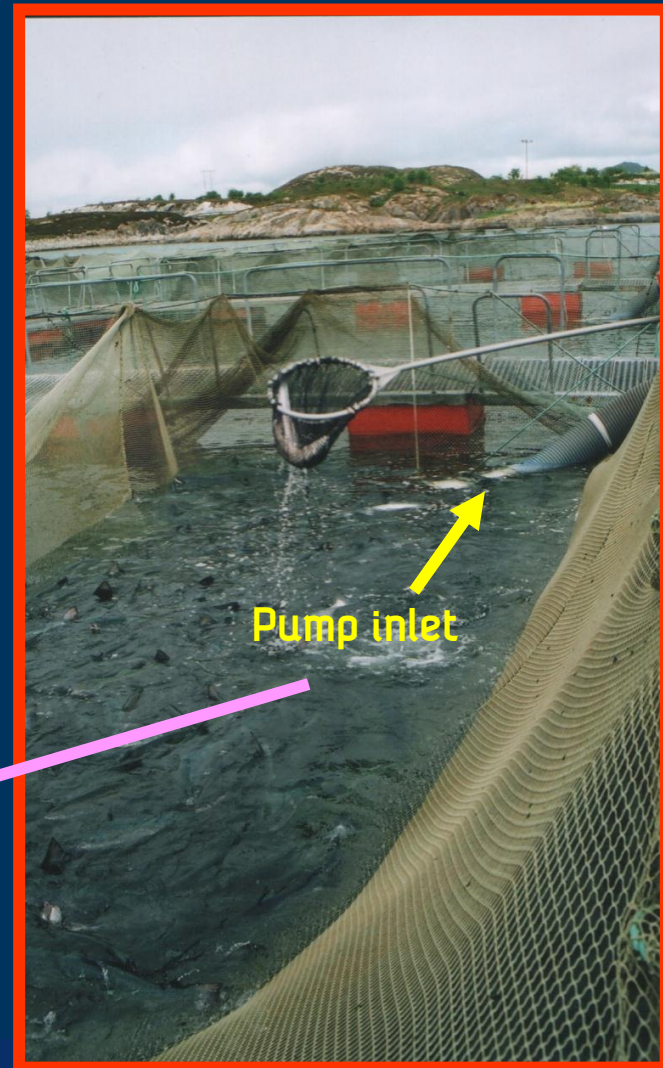

Carbon dioxide stunning

- $\text{CO}_2 > 400 \text{ mg L}^{-1} \rightarrow$ Low water pH
- Severe crowding (loss of scales)
- Struggling to exhaustion
- Fish immobilized after 2- 4 min
- Fish not rendered unconscious
Compromised welfare!
- Early onset of rigor mortis
- Reduced product quality



Electrical stunning after dewatering

Example:

40 – 110 V (pDC)

50 Hz (100 Hz)

- Electrical parameters very important
- Fish can be rendered unconscious
- Post stunning recovery! (no recovery for 10 min)
- Time to onset of rigor mortis reduced
- Filet blood spots and broken spines may occur



Changes in muscle pH before and after death



Initial pH (t = 0 h):
Effect of stress



Protein network shrinks (pre-rigor)

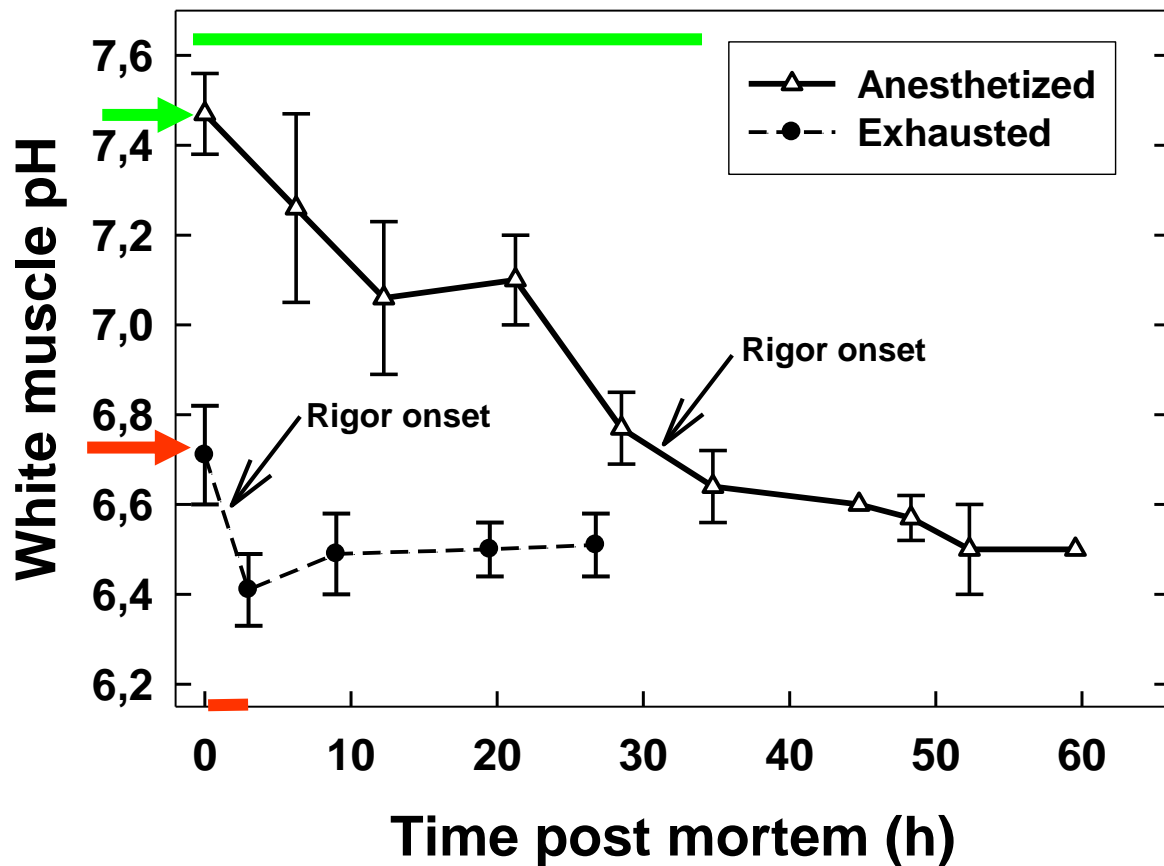

Unstressed and stressed fillets – Changes in shape

Area and length →

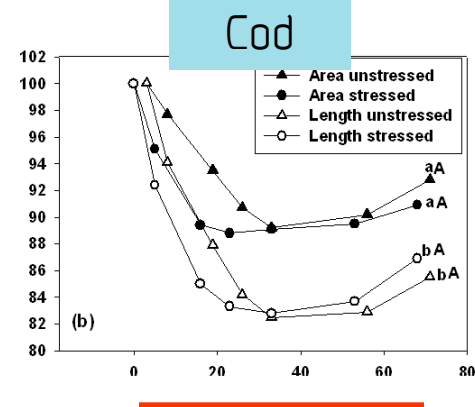
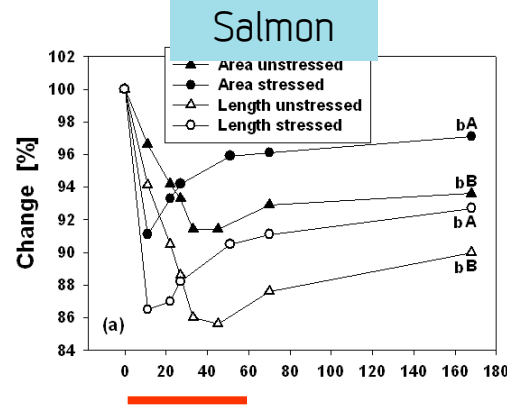

Width and roundness →

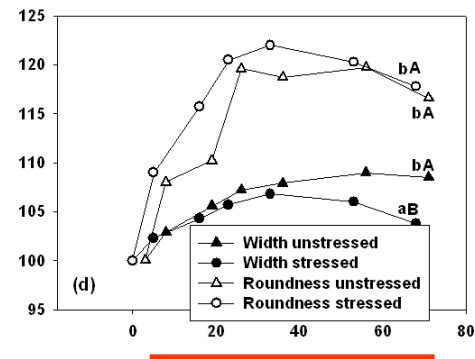
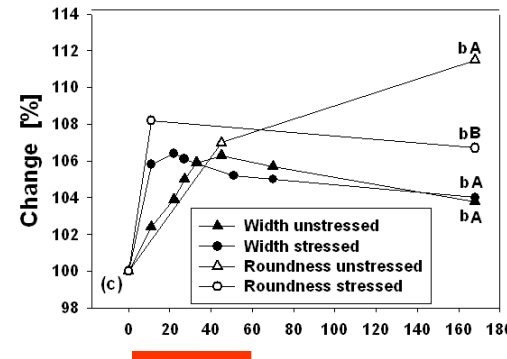

Cross-section height →

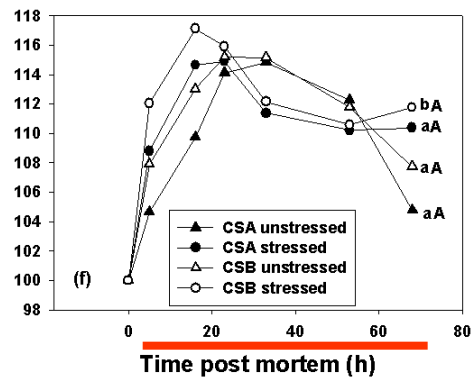
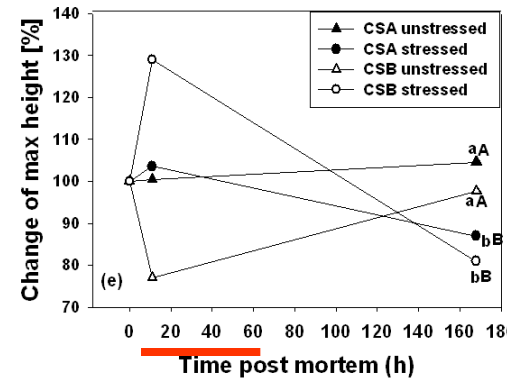

— Duration of rigor mortis

Misimi et al. (2008)

Stress and onset of rigor mortis

Pre-rigor filleting

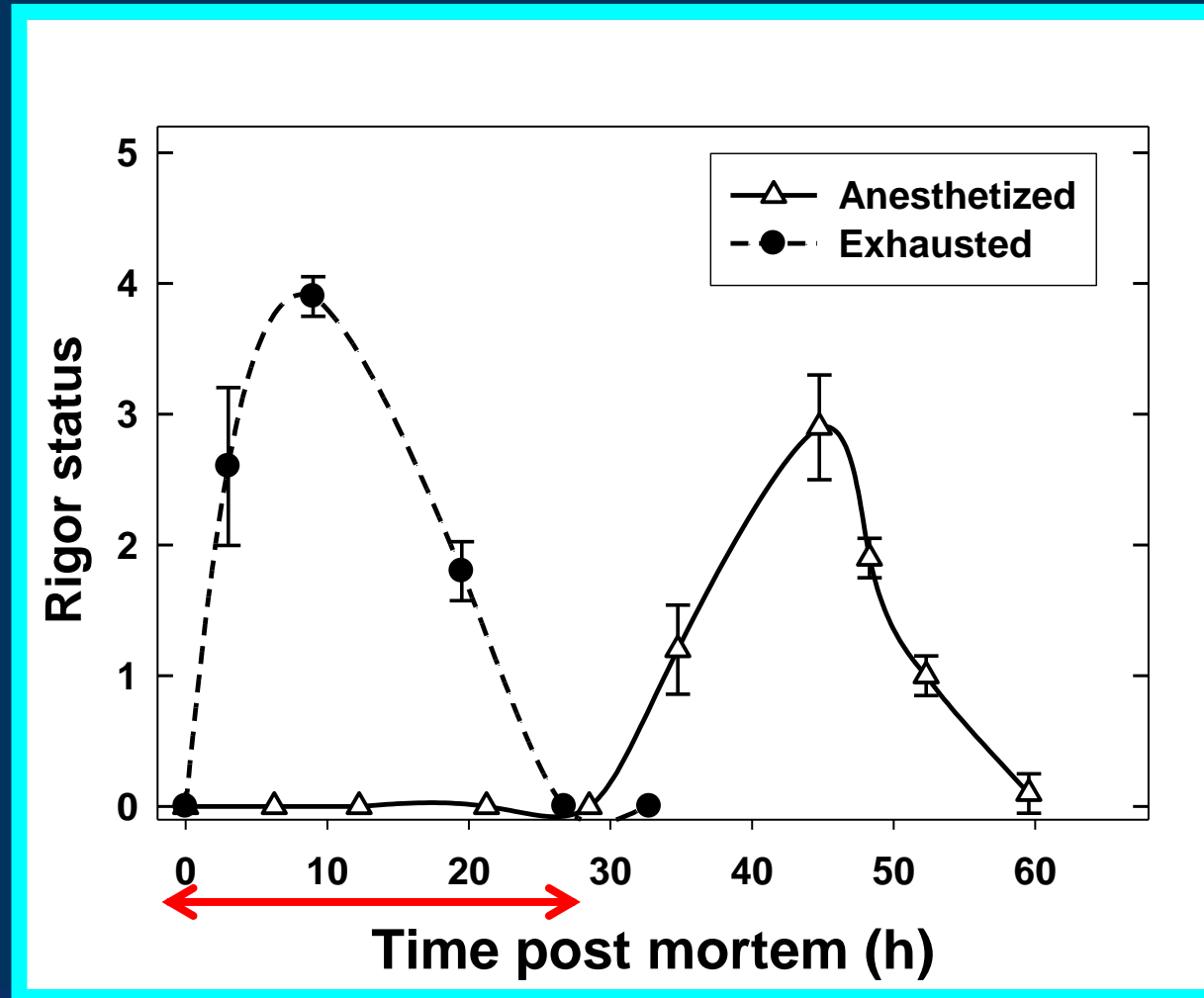

High muscle activity depletes energy reserves



Stress

- Phosphocreatine and ATP depleted
- Formation of IMP in vivo
- Reduced freshness

Post mortem degradation:

ATP → ADP → AMP → IMP

→ Inosine → Hypoxanthine

IMP = 'good taste'

Hypoxanthine = bitter taste

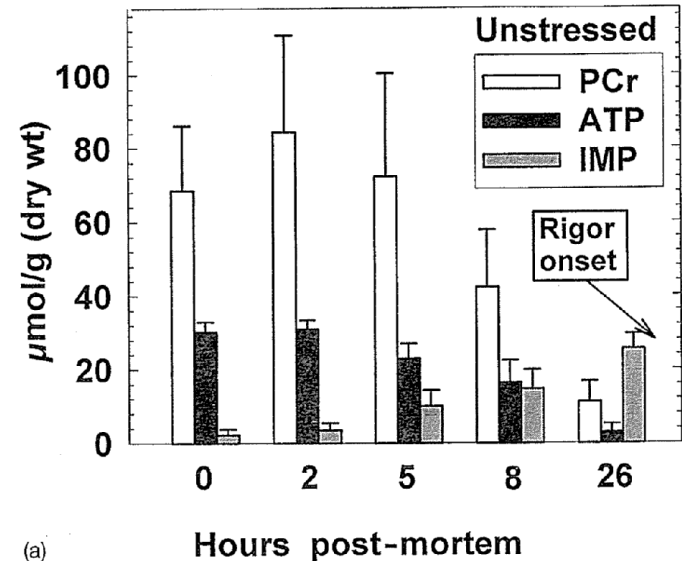

(a)

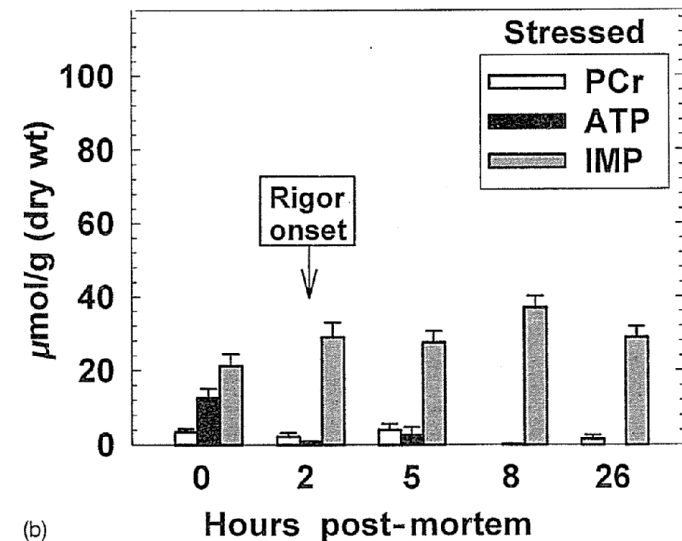

(b)

1H MRI: Tverrsnitt av laksemuskel som viser feste av pinnebein mot skinnside

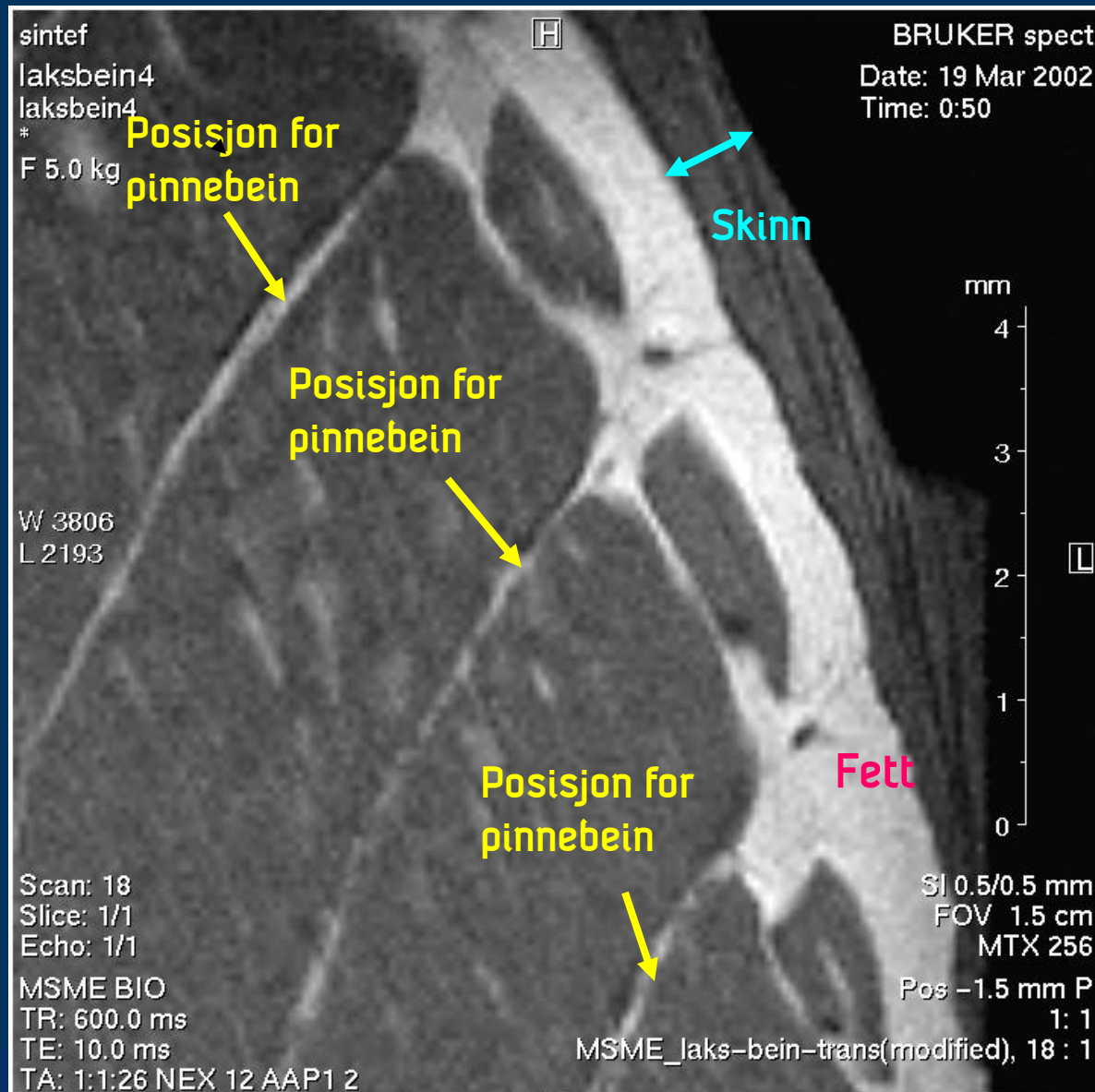

MR micro-imaging: Pinnebein i laks i to ulike tverrsnitt. Måling foretatt postrigor

Ovenfra (øverst) og fra siden (nederst)

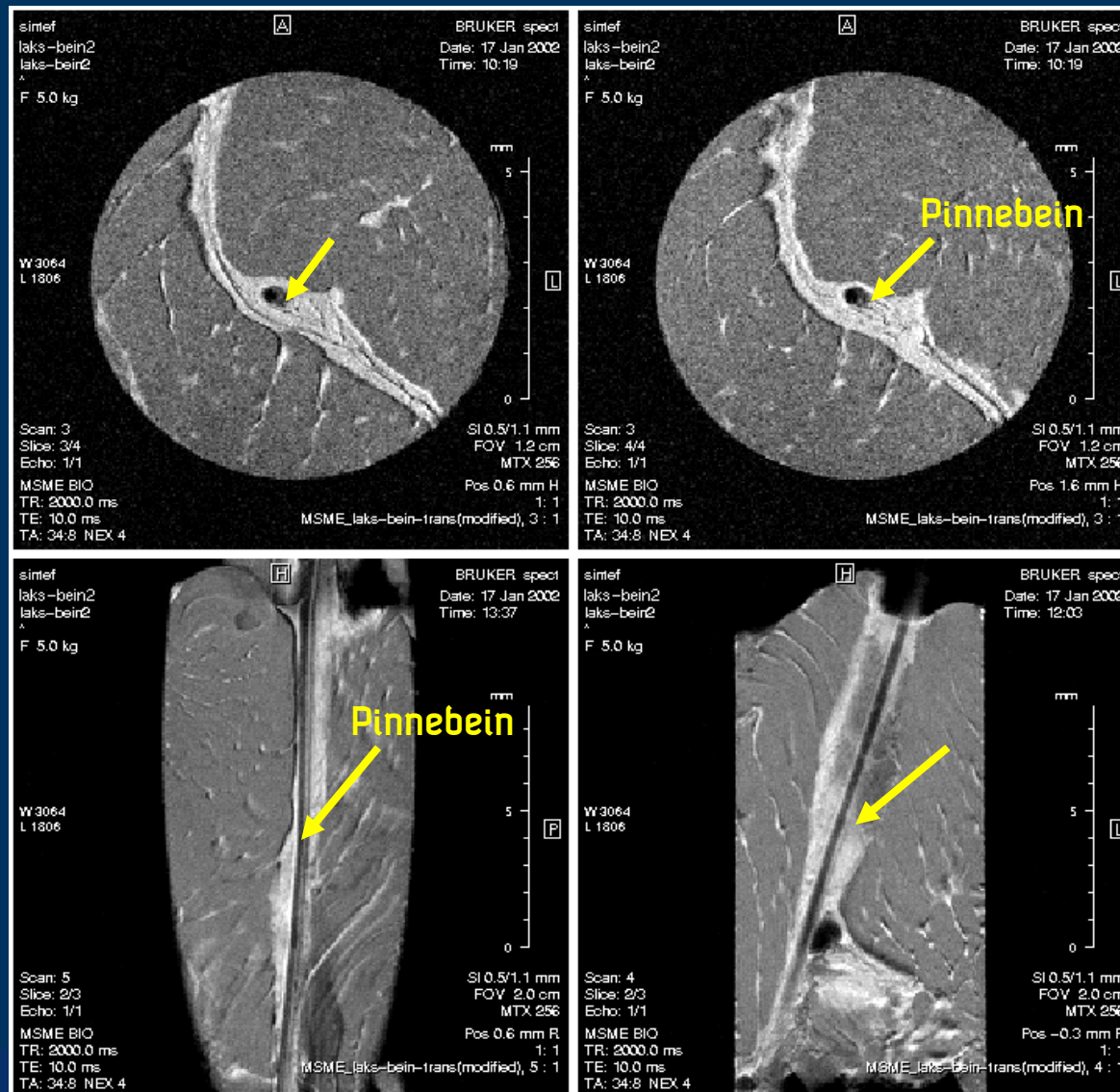

Post rigor!

Fjerne pinnebein i filét fra laksefisk

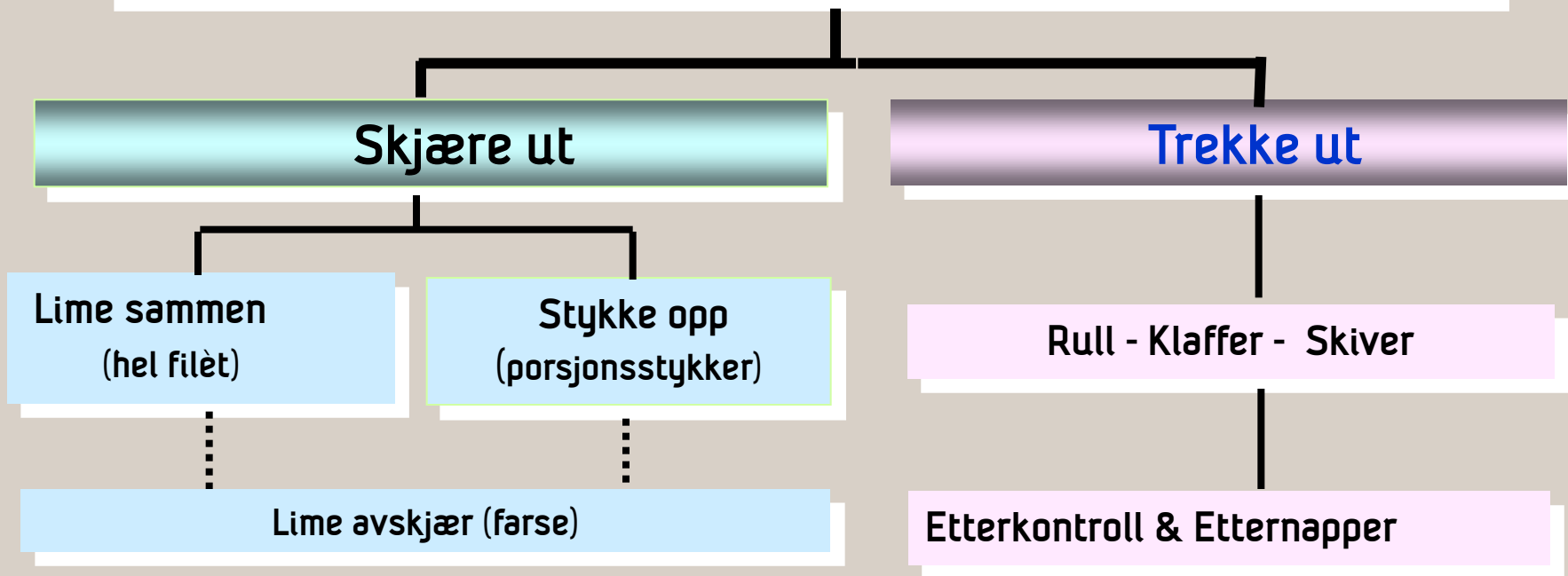

- Pre-rigor
- 100 % beinfjerning
- Utbyttetap

- I dag:
- Post-rigor
 - 80-90 % beinfjerning

Maskinell fjerning av pinnebein

Gjøres post rigor fordi beinene er lettere å trekke ut etter at fisken har passert rigor mortis

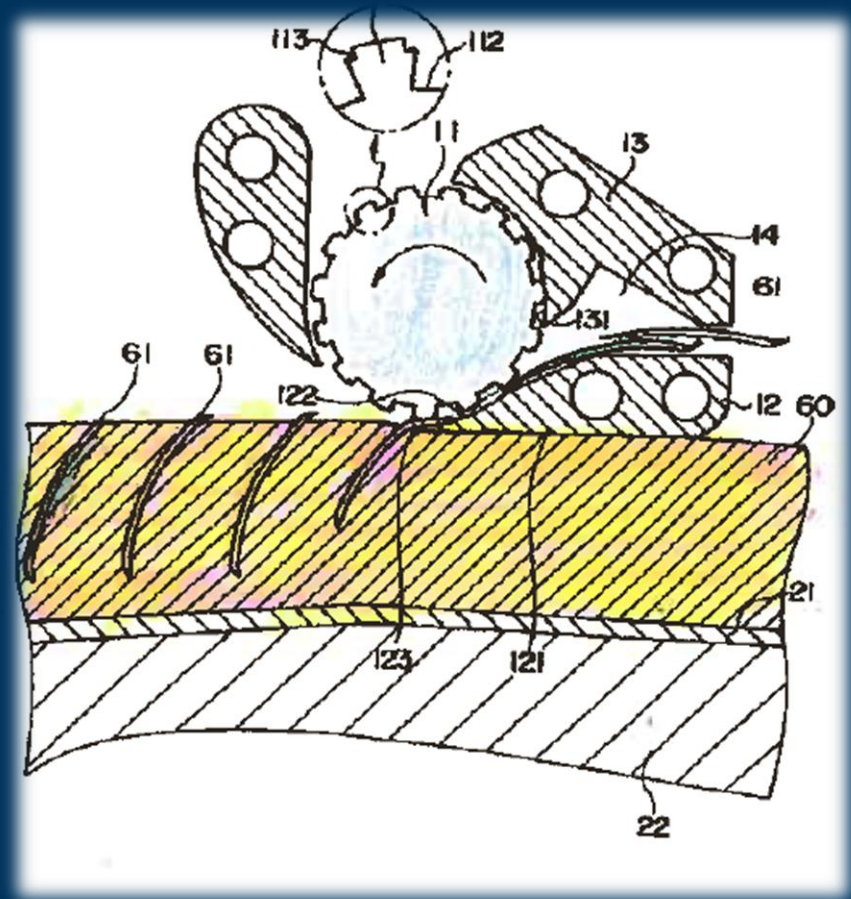

TBRS – Total Bone Removal System

Brukt på villaks i Alaska (Wadsworth, 1998)



Utskjæring av hele rekken med pinnebein

Lime sammen laksefilet ved bruk av transglutaminase (TG)

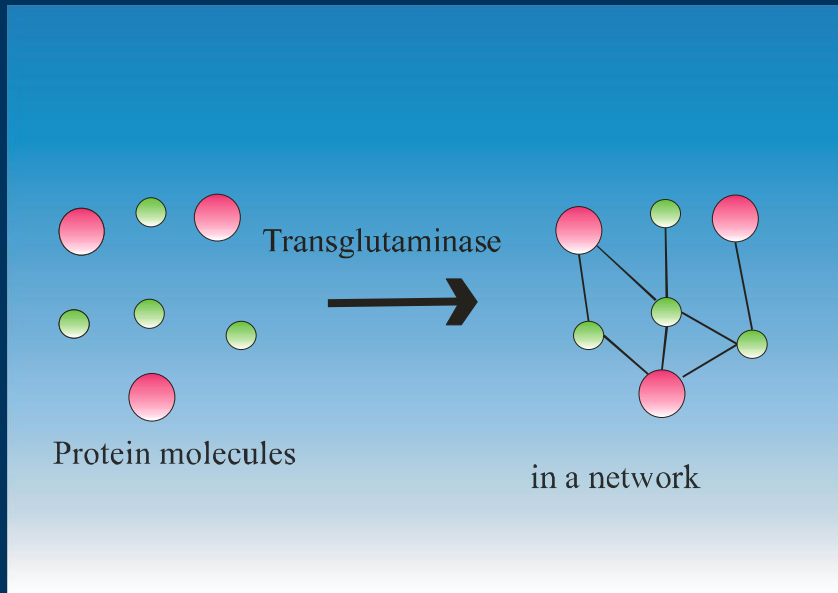

100 % beinfri laksefilet
Kuttesnitt restrukturert ved bruk av TG

Production line – Pin bone free pre-rigor salmon fillets

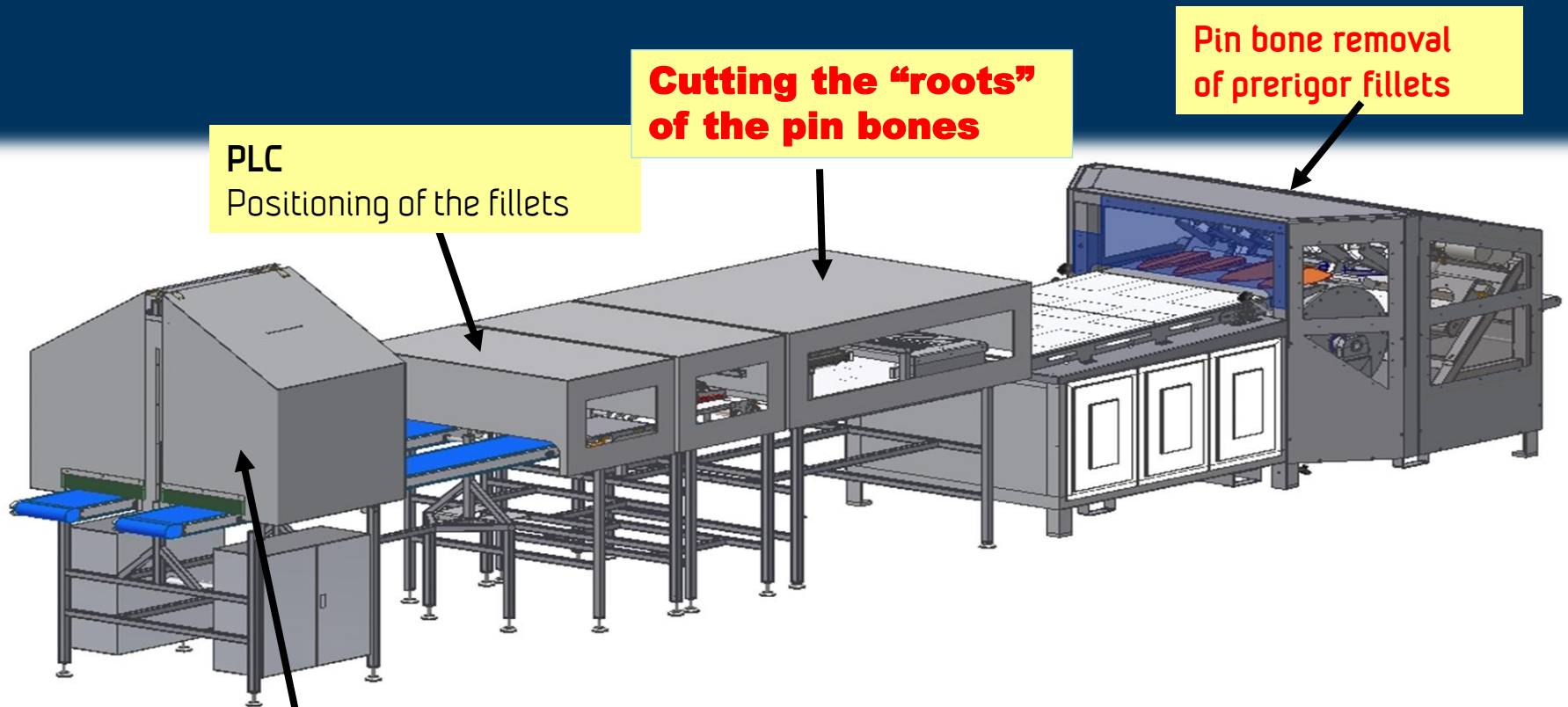

Made by
Trio Food Processing Machinery
Stavanger, Norway

Ny metode fra Marel

- Basert på gode erfaringer fra kyllingindustrien
- Beinfjerning lettere når muskelen er tømt for energi (glykogen og ATP) ★
- God produktkvalitet (kylling)

Trinn 1 : Elektrisk stimulering like etter slakting

- Egnede elektriske parametre?
- Hel fisk (?)
- Utstyr for automatisert elektrisk stimulering
- Hvor i prosesslinjen skal det gjøres??

Trinn 2: Uttrekk av pinnebein med (modifisert) tradisjonell maskin

marel

Pin bone machine



Innledende tester ved Marine Harvest

- Elektrisk stimulering av hel laks - bl.a. måling av nødvendig kraft for å trekke ut pinnebein (F)
- F påvirkes (i ukjent grad) av elektrisk stimulering
- Foreløpig ingen klare tegn til redusert filetkvalitet ('Industritest')

Prosjektforslag: Grunnleggende mekanismer (forutsetninger) for at pinnebein skal kunne fjernes pre-rigor fra laksefilet

- Parallelt med Marel sitt utstysrelaterte FoU-prosjekt
- Mekanismen for løsning av pinnebein skal ses i sammenheng med bl.a.:
 - a) Stress i slakteprosessen
 - b) Rigor mortis
 - c) Alder post mortem
 - d) Elektrisk stimulering

Takk for oppmerksomheten!

